

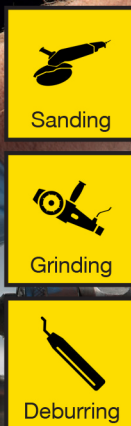

**MONSOON**  
WET DOWNDRAFT TABLE



The MONSOON™ Wet Downdraft Table product series delivers the safe capture of hazardous/combustible dusts with the smallest equipment footprint in the industry. This self-contained wet downdraft table's patent-pending design achieves a very high face-velocity at a very affordable price. A wide range of application kits and custom fittings can help you meet your NFPA and OSHA requirements.

The MONSOON™ series all include industrial swivel casters, adding mobility and versatility to your application. This wet filtration table is perfect for capturing combustible dust, including mixtures of steel, aluminum, titanium, and magnesium.

The MONSOON™ works by drawing dust-laden air through the table surface and into a cascading water bath. The wet downdraft table cleans the air by using the combined action of centrifugal force and a thorough intermixing of water and dust laden air. The dust is separated from the airstream by water droplets created by the flow of air through strategically placed baffle plates. Once wet, the dust becomes permanently trapped and falls down into a reservoir.

**Benefits:**

- Capture-at-source for Cleaner Air
- Complies with NFPA guidelines for Combustible Dust

**Features:**

- Auto-fill Water Control System (3X4, 3X6, 3X8)
- Anti-corrosion Stainless Steel Construction
- Motor Starter and a Non-Sparking Blower Wheel
- Low-cost mist eliminator afterfilters

**Options:**

- Auto Wash-down System
- WV-55 Sludge-Vac
- Side and Back Walls
- Hepa after-filter kit (99.99% @ 0.3 micron)
- Dust-Tight/Vapor-Tight Light Kit
- Auto-fill Water Control System (MDD-MINI)

*\*Custom configurations available on request.*





**Models**



MDD-MINI and MDD-3X4 shown with optional side and back walls.

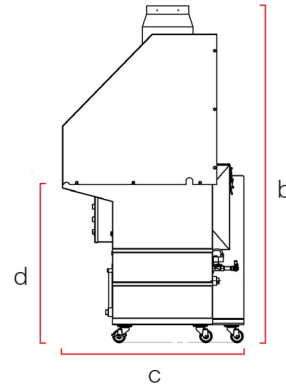
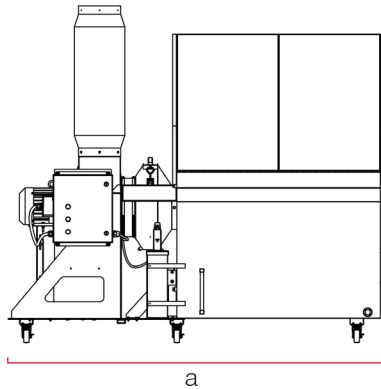

**Dimensions \*\***

Model	Footprint (in.)			Net Weight (lbs.)	Worksurface (in.)			Water	
	Width [a]	Height [b]	Length [c]		Width	Height [d]	Length	Supply (in.)	Drain (in.)
MDD-MINI	68	74	41	542	30	41	36	1/2 NPT	1 1/2" NPT
MDD-3X4	90	81	44	621	49	41	36	1/2 NPT	1 1/2" NPT
MDD-3X6	117	87	44	646	73	41	36	1/2 NPT	1 1/2" NPT
MDD-3X8	142	102	57	810	98	41	36	1/2 NPT	1 1/2" NPT

1. Water Level is marked on each unit.

\*\* Product dimensions are based on base-models and may vary depending on selected product features. Please contact us for an accurate shipping quote.

**Technical Specifications**

Model	Water Fill System	Nominal Airflow (CFM)	Tank Capacity (Gallons)	Motor (H.P.)	Power				Noise @5ft. (dB)
					Phase (hz)	@230V (amps)	@460V (amps)	@575V (amps)	
MDD-MINI	manual	1200	23	3.0	3P / 60Hz	9.6	4.8	3.9	75
MDD-3X4	auto	3000	40	5.0	3P / 60Hz	15.2	7.6	6.1	72
MDD-3X6	auto	5000	60	10.0	3P / 60Hz	28.0	14.0	11.0	78
MDD-3X8	auto	6500	60	15.0	3P / 60Hz	34.0	16.9	14.0	80



Innovative Air Solution Specialists

Website: [www.airsolutions.us](http://www.airsolutions.us)

Email: [mail@airsolutions.us](mailto:mail@airsolutions.us)

Phone: 901-290-5090

Air Solutions, Inc.

P.O. Box 508

Oakland, TN 38060